

ThermCAM-160

Long Wavelength
Ultra Compact Infrared
Camera for Non Contact
Temperature Measurement Solutions



ThermCAM-160 is a versatile thermal camera which can be used for a wide range of temperature measurement applications. ThermCAM-160 with resolution of 160 x 120 pixels, provides optimum image resolution as well as thermal data transfer to PC via 100 Mbps Ethernet connectivity. With InfraView™ Software, it can fit many industrial applications off-the-shelf. Whether in quality control, process monitoring or process automation ThermCAM-160 measures temperature of each pixels consistently and accurately .

Product Highlights

- ThermCAM-160 works at a long wavelength range from 8 - 14 μm.
- Configurable storage and temperature video recording.
- Provide continuous thermal video in InfraView™ Software in PC via an Ethernet connectivity.
- High shock and vibration tolerance for maintenance-free operation.
- Multiple ThermCAM-160 can be connected to a single InfraView™ Software.

Typical Applications

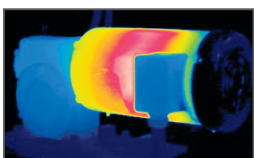

Critical Assets



HVAC Inspection

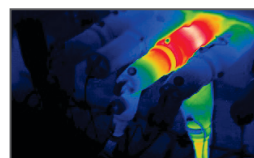

Electric Equipment Inspection

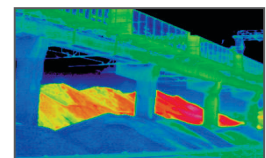

Early Fire Detection



Conveyor Belt Monitoring

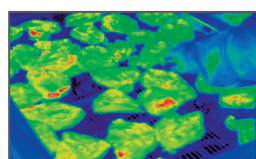

Quality Management

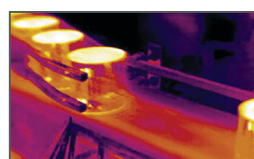

Process Automation



Research and Development

Temperature Ranges

- -20°C - 120°C
 - 100°C - 1000°C
- } Switchable via Software

Detector

Uncooled FPA detector with 160 x 120 pixels resolution.

Measurement Accuracy

±2% of reading in °C or °K

Software Features

- Different Types of ROI for localized temperature monitoring and measurement
- Histogram and Trend Chart of ROI.
- Configurable Audio/Visual Alarm.
- Configurable Alarm output to I/O module.

Output Interface

- Fast thermal data acquisition in real time via 100M-bit Ethernet with built-in 4-20mA, TTL O/P.
- Digital and analog input/output modules

ThermCAM-160

Overview

The compact design of the ThermCAM-160 enables the integration of the camera into compact process applications, while the durable and robust housing guarantees reliability even in most harsh industrial environments. The ThermCAM-160 can be installed with an optional IP67 enclosure with air purge unit for additional protection in harsh industrial environments where ambient temperatures exceed $\sim 60^{\circ}\text{C}$.

The built-in 100M-bit Ethernet allows the camera to be connected to the System for high speed data transmission to InfraView™ software for further analysis.

Optics Variants

A wide range of lenses are available for the ThermCAM-160, making it suitable for most industrial applications. The table and picture show the correlation between the measurement distance, different optics, and the size of the measurement fields.

Measurement Field (HFOV x VFOV)	Distance of object	Width (m)	Height (m)	Pixel WxH (mm)
31° x 23° (FL = 5 mm Fixed)	1M	0.55	0.40	3.43
	5 M	2.77	2.03	17.14
	10 M	5.54	4.06	34.29

Note : Other lens options are also available as per application requirements.

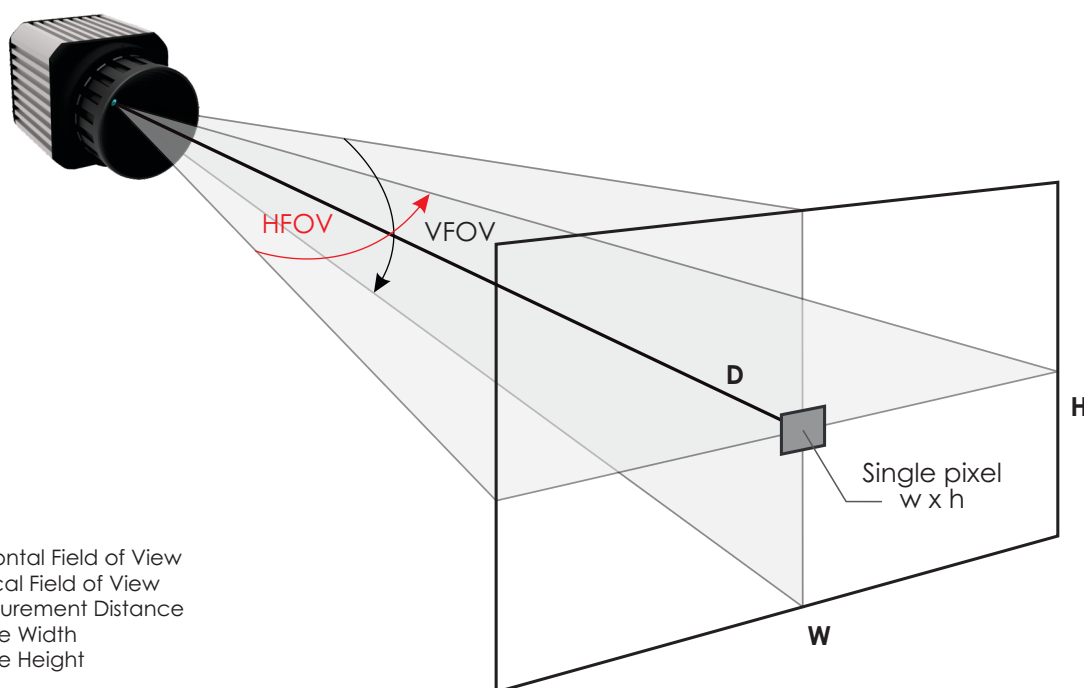

SYSTEM CONFIGURATION

AccuOpt thermal imagers offer several configuration options.

ThermCAM-160 Over Network

The system can be set up by connecting the camera directly to a dedicated computer using Ethernet connection which can be extended for remote access/intranet. Also camera can be paired with a network device (switch) which can be further connected with I/O module to get alarm/alerts, analog/digital output for digital indicator and PLC/SCADA systems.

1. ThermCAM-160 without PoE Configuration

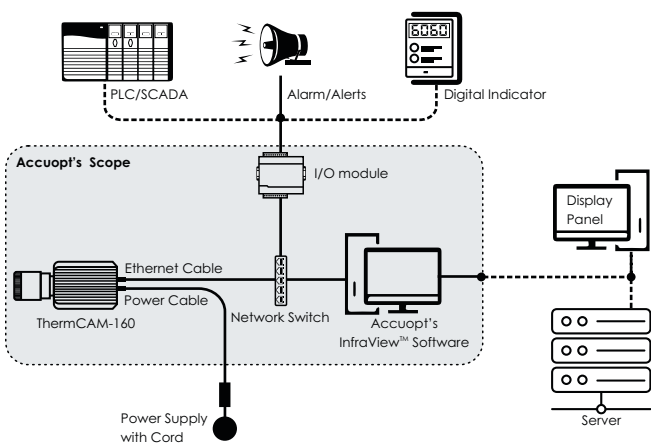

2. ThermCAM-160 with PoE Configuration

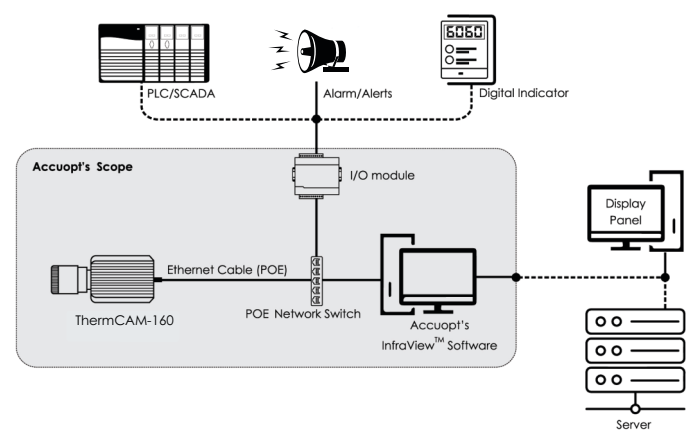

ThermCAM-160 Standalone System

Additionally, the camera can be used without a desktop PC or a laptop for the standalone monitoring system. One-time parameterizing is required to configure camera in the standalone mode.

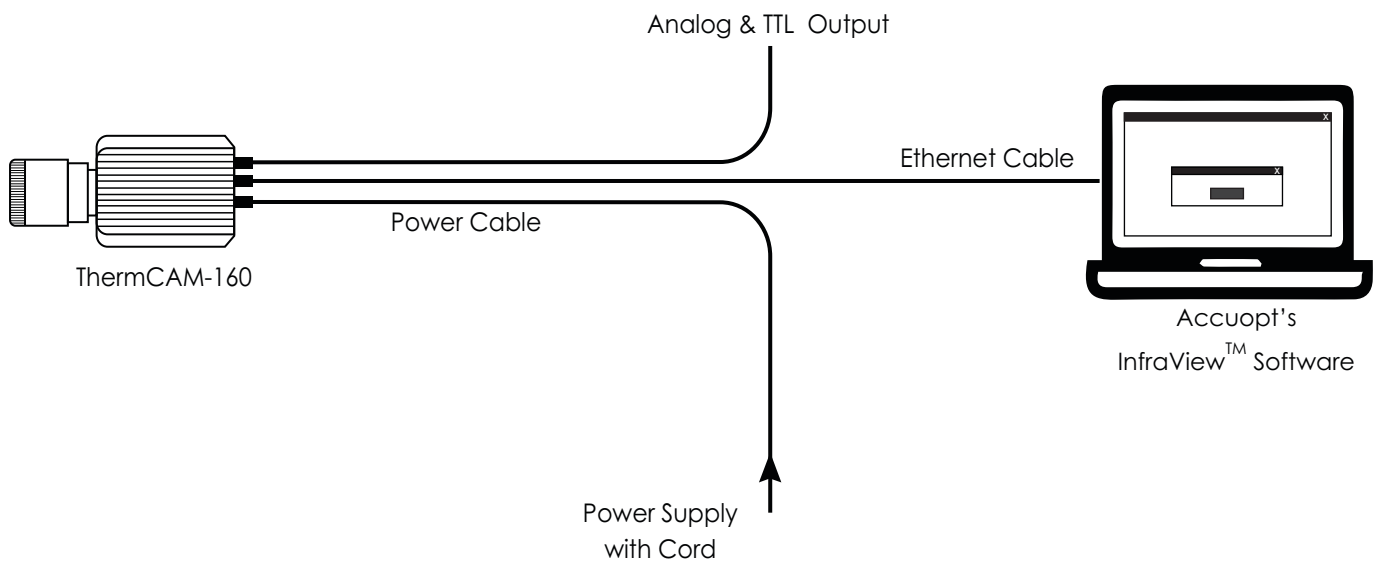

ThermCAM-160 comes with thermal image processing software InfraView™ at the core of a thermal imaging system which is Windows based Software with many useful features.

AccuOpt's InfraView™ software allows you to stream thermal video on a PC, record thermal video, Draw ROI (Region Of Interest) in various shapes and sizes. It allows computed temperatures to be sent out via I/O card which in turn can be connected to PLCs.

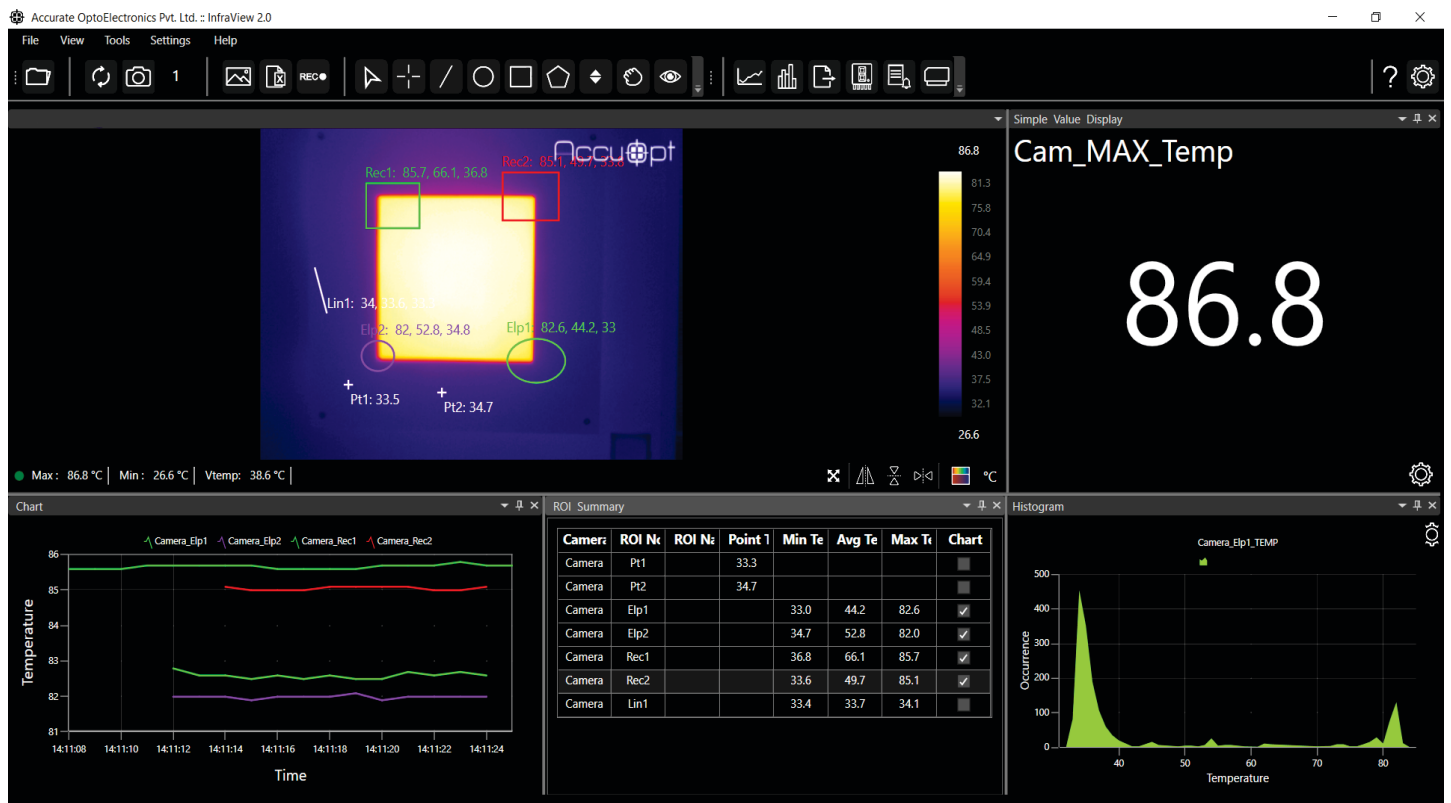

SALIENT FEATURE LIST FOR INFRAVIEW™ SOFTWARE

- Configurable emissivity, Transmissivity Settings
- Real-time display of thermal images
- Includes 9 different color palates
- Multiple types of ROI including point, line, and area with min./max./avg. temperature display
- Includes analysis tools like histogram and temperature trend chart for multiple ROI's.
- Alarm generation for entire or ROI based on minimum, maximum or average temperature
- Analog and digital output module
- Triggered capture based on alarm conditions
- Password controlled user access
- Data export to text or Microsoft Excel (includes thermal image, ROI table summary/data, image data) or to text
- Analyze previously recorded images using RAW data
- Saving Thermal Video in MP4 format
- Optional SDK
- Additional software for Real Time Temperature dashboard, analysis and report generation.

STANDARD ACCESSORIES

- PoE Cable
- Power Cable Cable
- Standard Infraview™ Software
- Lens
- SMPS

OPTIONAL ACCESSORIES

Water Cooling Jacket with Air Purge

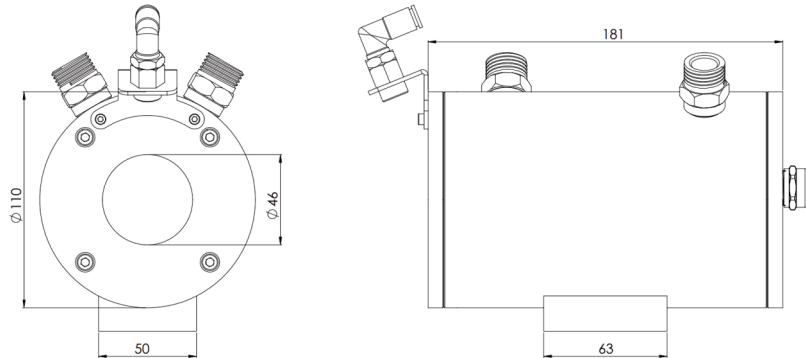

I/O Module



I/O Module

The I/O module consist of digital input/digital output(relay output) and analog 4 - 20mA, which can be mounted on Din-rail. It provides analog and relay outputs with respect to temperature. These outputs can be customized for temperature indication, alarm generation or error reporting.

- All I/O are user settable for range and ROI selection
- I/O Channel parameters can be customized via software, as per requirement
- I/O works on Ethernet and provide with Din rail Mounting for Easy Installation

Workstation/Laptop (for Single Camera Only)



- Processor : Intel i5 8th Generation or Higher
- RAM : 8 GB
- HDD : 1 TB or Higher
- SSD : 256GB
- 2 Nos Gigabit Ethernet or USB 2.0 port
- Operating System : Windows 10Pro

Wall Mounting

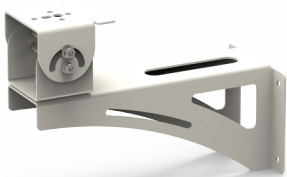

Power Supply



Tripod



Network Devices



TECHNICAL DATA

Performance Specifications	
Temperature Range	-20°C to 120°C 100°C to 1000°C (Switchable)
Optical Resolution	160 x 120 pixels
Detector	Uncooled FPA Detector
Frequency	30Hz
Emissivity	0.01 - 1.0 adjustable
Accuracy	±2% of reading in °C or °K (Ambient temp @25°C)
Spectral Range	8 to 14 μm
Sensitivity / NETD	<60mK@f1.0, 50Hz 300 K
Pixel Pitch	17 μm
Interface Specifications	
Video	100MBit/s Ethernet
Connection	Power Connector, RJ-45 Ethernet Connector
Output	1 Analog (4 - 20mA) 1 TTL output
Video Format for Saving	MPEG-4
Image Format for Saving	BMP/JPEG
Electrical Specifications	
Power Supply	12 to 24 V DC
Power Consumption	<4 Watt Max.
Environmental / Mechanical Specifications	
Ambient Temperature	0°C - 60°C
Storage Temperature	-40°C - 70°C
Relative Humidity	<95% non-condensing
Shock Resilience	25g
Vibration Resilience	2g
Weight	~550 gms (with 5mm lens)
Protection Class	IP65
Size	60 x 60 x 95 mm (with 5mm lens)
Mounting	UNC 1/4"-20 , UNC 3/8"-16 Standard Mount
I/O Module Specifications	
Analog Output	4 Channel Analog Current Output (4 - 20mA)
Digital Input	2 Isolated Inputs
Digital Output	2 Relay Outputs
Power Supply	5 V DC
Cooling Jacket Specifications	
Inlet/Outlet (Cooling)	½" BSP Thread
Inlet For Air Purging	PU Pipe suitable for 6mm nozzle
Water Flow Rate	6-8 L/min
Air Pressure	Min. 3 bar (Moist Free)
Mounting	5 x M5 thread
IP Rating	IP 67

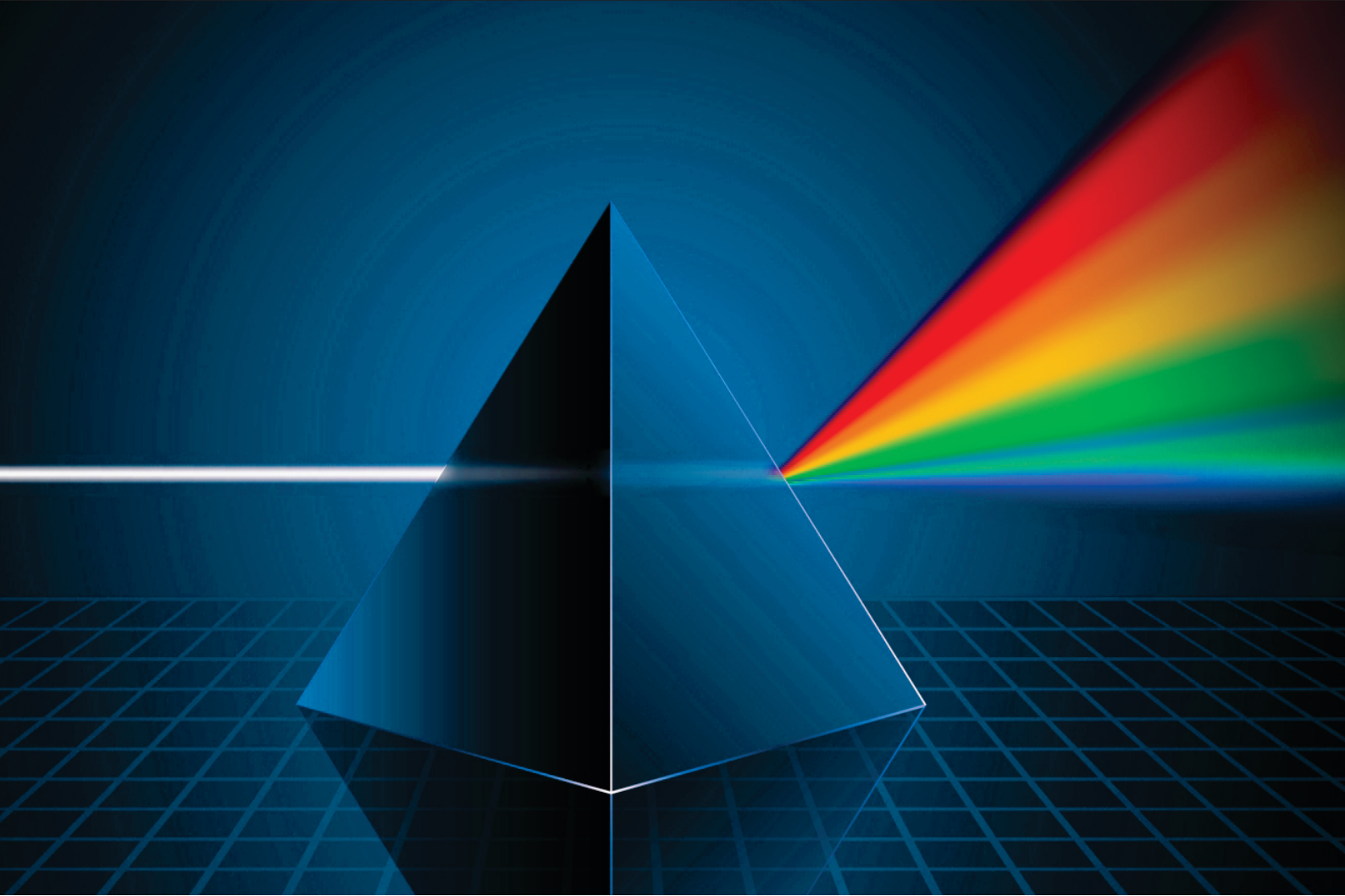

AccuOpt

for any information,
visit www.accuopt.com

sales@accuopt.com
+919352506032, +91 8306006472

ABOUT ACCURATE OPTOELECTRONICS

AccuOpt – Accurate Optoelectronics Pvt Ltd. is a world-leading manufacturer of thermal imaging camera and solution. Based on technological innovations, AccuOpt Technology offers parts or end-to-end solutions for Industrial, Defense, Surveillance and Medical fields.

Specifications are subject to change without notice. Not responsible for errors or omissions. Accurate Optoelectronics Private Limited.